

Double countertop basin / cutable

81470.6



TECHNICAL DATA

Order no.	81470.6
Certified to	EN 14688
Dimensions	1500 x 380/510 mm
Inside dimensions of the basin	565 x 365 mm
Specification	Always to be fixed to the wall. Cut one-sided to 1350 mm incl. towel rail order no. 38170.5 Charge 104 – per basin 1 centre tap hole, with overflow
Special specification	Charge 111 – per basin 1 centre tap hole, without overflow Charge 108 – per basin 3 tap holes, with overflow Charge 136 – per basin 3 tap holes, distance 8 inches, with overflow Charge 158 – per basin 3 tap holes, without overflow Charge 109 – without tap holes, with overflow Charge 112 – without tap holes, without overflow per basin 1 centre tap hole, 1 hole left and right for soap dispenser Charge 806 – with overflow Charge 818 – without overflow 1 tap hole left and right, 1 hole left and right outside for soap dispenser Charge 807 – with overflow Charge 819 – without overflow

Special specification	per basin 1 centre tap hole, 1 hole right for electronic valve unit to control the temperatur of the water and the flow rate Charge 814 – with overflow Charge 815 – without overflow per basin 3 tap holes, 1 hole left and right for soap dispenser Charge 810 – with overflow Charge 823 – without overflow
Weight	34,0 kg
Mounting acc. excl.	2x Mounting set M10 x 140 mm, order no. 89988.2
Otherwise	When ordering the cut version use the order form for cutting
Colours	see colour table

SPECIFICATION TEXT

Cutable double countertop basin Laufen-PALACE, sanitary ceramic EN 14688, dimensions 1500 x 380/510 mm, symmetric per basin 1 centre tap hole
Special feature: overflow channel glazed, cutable to 1350 mm, integrated shelves, with towel rail
Further options / accessories: Surface refinement LCC (only white), 3 tap holes, without tap holes, with or without overflow, hole for soap dispenser left and right, electronic valve unit to control water temperature and flow rate, 3 tap holes distance 8 inches with overflow, furniture
Order no. 81470.6

TECHNICAL DRAWINGS / S 1 : 20

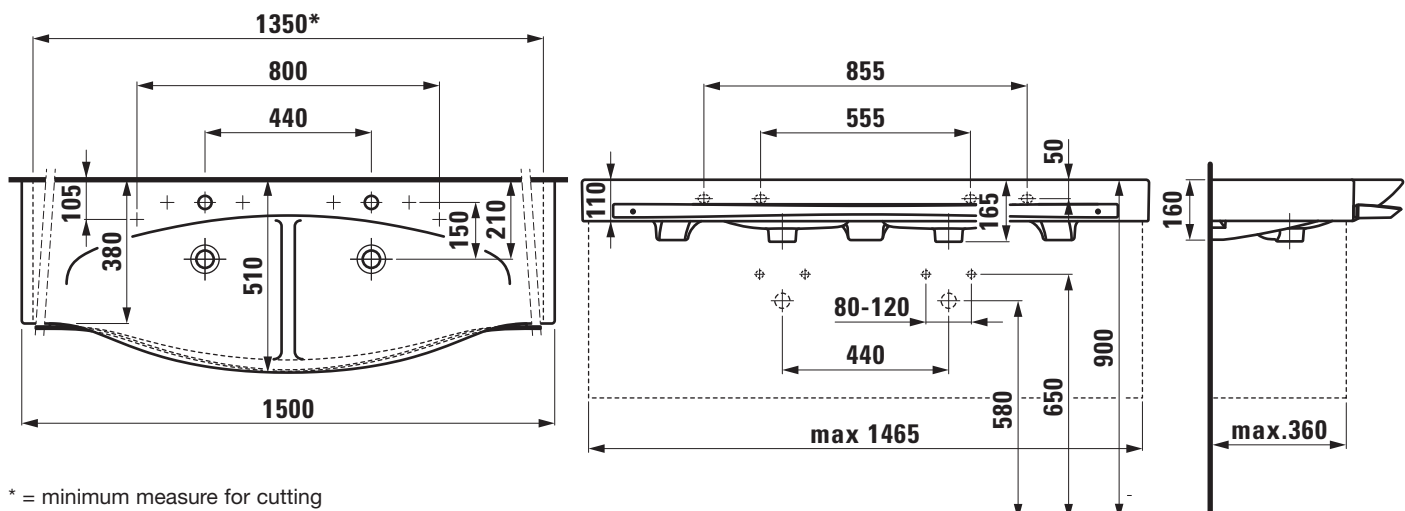

* = minimum measure for cutting